

Checking System of Dust and Humidity in Environment utilizing Arduino and Internet of Things

Sanjay Kumar Padhi¹ and Purnya Nayak²

¹Aryan Institute of Engineering & Technology, Bhubaneswar, Odisha

²Capital Engineering College, Bhubaneswar, Odisha

Abstract : In foundation and mechanical plants the fast development making ecological issues like contamination (Air, environmental change, failing and has significantly ramification for the necessity of an, functionally versatile, productive, modest and brilliant observing frameworks. In this setting where blend of many difficulties of software engineering, remote correspondence and gadgets; the Smart Sensor Networks are an arising field of examination. In this paper an answer for screen the air and clamor contamination levels in mechanical climate or by utilizing remote installed processing framework a specific space of interest is proposed. The innovation like Internet of Things (IoT) is remembered for the type of arrangement which is result of consolidated field of software engineering and hardware. For observing the vacillation of boundaries like air contamination levels from their typical levels for this situation the detecting gadgets are associated with the inserted figuring framework. For the prerequisite of ceaseless checking, controlling and conduct examination this model is versatile and distributive for any infrastructural climate. The functioning appearance of the proposed model is assessed utilizing model execution, comprising of arduino nano board, sensor gadgets For a few boundaries like stickiness, temperature, dust levels the execution is tried regarding the ordinary conduct levels or given determinations which give a checking over the contamination control to make the climate brilliant and ecofriendly.. Here we propose an air quality contamination observing framework that permits us to screen and check live air quality in specific regions through IoT. Wi-Fi module, temperature, mugginess, gas, and residue sensors are interfaced with the arduino.

IndexTerms - Sensor, Carbon Monoxide Sensor, Ardiuno IOT,WiFi..

I. INTRODUCTION

Nowadays, the Wireless Sensor Network (WSN) is considered to be an essential technology that is used in many fields and projects such as monitoring the water quality, engine emissions and air pollution and metrological. It is made of nodes, every node or more than one node is connected to one sensor. The WSN had many advantages which are sufficient data, temporal accuracy, flexibility, low power consumption, less implantation cost and so on [1]. The wireless sensor network can be an excellent device to observe air quality. It gathers air quality data automatically. Due to depending on industrial and fossil fuel in over the world, toxins and unhealthy gases and radiation that in many cases cannot be detected by smell or sight surround by humans. These gases and radiations have many potential dangers such as lung damage, skin damage, and even cancer and death, not to mention the possibility of explosive gas damage This paper presented an approach to prevent such dangers in a reliable and affordable way. Many hardware can be used to implement this work such as arduino nano, IOT ,Dust sensor and so on. This project aims to prevent such dangers by using the arduino nano because of its features and characteristics, which are:

- 1) Relatively low-cost.
- 2) Easy to program and understand.
- 3) Portable computer and pocket size device.
- 4) Many sensor nodes can be hooked up to it.

II. LITERATURE SURVEY

1. Industrial Air Pollution Monitoring and Analysis System:[1] The system existing before was based on microcontroller based toxic gas detecting and alerting system and the developing system will have a complete monitoring system which is IOT based. As monitoring is done continuously, we can release and share monitoring news at real time too. The positioning, analyzing and synchronous display can be done with the help of Web GIS. The controller makes out a decision plan with the database of inquiry rules, and traces the implementation of the program. This system could make real time remote monitor dynamically and accurately toward the monitor scope. It will help us to keep a working staff away from danger and a high security can be achieve and it will also help the Government authorities to monitor the harmful gases emission as "Global Warming" perspective too.

2. Smart Pollution Detection and Tracking System Embedded With AWS IOT Cloud: The main objective of this paper is to implement IOT to measure the pollution of public transports using MQ7 Arduino which is sensitive for Carbon Monoxide. Global Positioning System (GPS) is implemented in these arduino which would find the location of the transport vehicle.The amount of Carbon Monoxide emitted is sensed once in (say 20km) and also the locality of vehicle is used for finding the area which is polluted the most. These are then integrated to the Amazon Cloud IOT which is more securable and many services of AWS can be used along with it. This would enable a Simple Notification Service (SNS) to the mobile phone when the vehicle is causing higher level of pollutants. 3. Automated System for Air Pollution Detection and Control in Vehicles:

3The aim of the project is to monitor and control the pollutants in the vehicle by using the pollution control circuit. This pollution control circuit consists of various sensors like smoke sensor, temperature sensor and GSM, GPS kind of devices, and all of them are integrated and

connected to a Controller. It is a real time work where a demo application has been made in which ARM 7 processor is used and a controller board is made where all these devices get integrated and work accordingly. The vehicle is controlled by this circuit. When a vehicle attains certain threshold pollution level then the engine gets automatically switched off and an SMS is generated and sent to the pre-defined number stored in the memory through the GSM module. The GPS module is used to locate the vehicle position where it is halted. This paper demonstrates an effective utilization of technology by which we save our environment by controlling the pollution of vehicles. By 2017, Rohani et al. used Arduino microcontroller with Open Platform Communications (OPC) in designing a monitoring system to control and monitor the CO₂ emission in the industrial environment. System testing was performed in a lab under real-time CO₂ emissions measurement, and system implementation indicated a successful application [10].

A real-time monitoring system for agriculture's weather was proposed by Susanto et al., which used parallel processing, Arduino, and Arduino nano. The system was faster and 50% efficient than the systems with single processor [11]. Furthermore, Mekki and Abdallah implemented a monitoring system for greenhouse controlling using Wireless Sensor Networks (WSN). Temperature, humidity, and soil parameters were controlled by the proposed system [12].

Abd Allah et al. presented a data logger system that can be used in applications of environmental monitoring. The system is universal, it is built using Arduino and LabView software, and can be used as a standalone device. It can monitor and record a massive amount of data [13].

Baharun et al. used the SICK sensor in conducting a study on measuring and analyzing the air quality inside the Meru Menora Tunnel. The study helped in controlling the ventilation fan system, which operates efficiently depending on the gases concentration level in the tunnel and thus eliminates the power consumption [14]. Montanaro et al. presented an air pollution monitoring system for the city, called SmartBike. The system exploited a network of bicycles to provide several services to citizens, such as bikes location detection, antitheft, traveled distance, and monitoring of air pollution [15].

III. PROPOSED METHODOLOGY

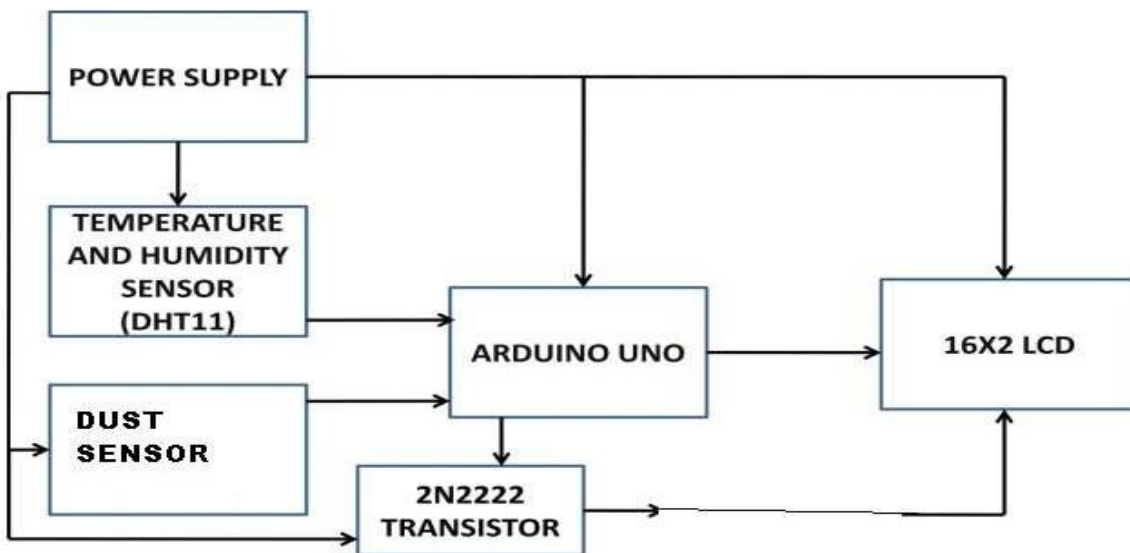

Figure 1 Block Diagram of Proposed System

. In Figure 1, the input detect values coming from the dust sensor and Dust sensor is responsible in detecting particulate matter The values will be sent to the arduino nano which is the channel in sending the IoT-Based notification sent to residents of the community that registered in the monitoring system.

. Dust sensor and CO sensor are used in detecting the air pollution. The dust sensor used is SHARP GP2Y1010AU0F Compact Optical Dust Sensor which has an IRED (infrared emitting diode) as well as phototransistor. This dust sensor can detect very fine particles. The dust presence can be detected by the photometry of only one pulse. The carbon monoxide sensor used is MQ-7 Gas sensor. It detects by method of cycle high and low temperature. The sensor has good sensitivity to carbon monoxide in wide range. Its conductivity is much higher along with gas concentration. As dust sensor and carbon monoxide works together, the dust sensor, detects particulate matter and carbon monoxide can detect the gas or carbon monoxide concentration on the range of area. The sensors are connected to arduino nano which channels in sending an email notification to the cloud server once detected values are on high level. A red light will turn ON upon detecting the high measurements

IV. WORKING

The parameters are then send to the microcontroller. In this project, it is used mainly for detecting household. The ionized constituents are detected by the sensing element, which creates a potential difference thus giving output in the form of current. The concentration of the gas detected is then send to the arduino nano. It has both the analog and the digital output but here we use the analog output which is connected to the analog pin of the microcontroller. DHT11 sensor is used for measuring humidity and temperature of the surroundings but, here I had used it for measuring only the humidity. The sensor provides fully calibrated digital outputs for the measurements of the parameters. It sends a data of 40 bits both for the temperature and humidity which also includes the checksum byte (bit error check). It operates at a voltage of +5v and gives the digital output connected to any of the digital pin of the microcontroller.

ESP8266 module is a Wi-Fi module, which the backbone of this project. Here it is used for connecting the microcontroller to an access point (Wi-Fi). This module has inbuilt set of Attention Commands which are required to configure the module. Firstly we flash the ESP8266 module using the software then using the Attention Commands it is set in the Wi-Fi mode and then it is connected to a mobile hotspot or a Wi-Fi, which finally connects our microcontroller to the WiFi. We create a channel (private) to view the changes in the parameters. The data is displayed graphically on the channel. One can get the access to the channel by getting the user ID and the data is transmitted to the channel by using the write API key provided by the channel, which enables our microcontroller to send the data. It requires a time of 15ms to update the data.arduino nano is one of the varieties of microcontroller based on , which takes input from the sensors and is connected to the Wi-Fi with the help of the Wi-Fi module which enable it to transmit data to the channel. The whole processing required is done by the processor in it.

Starting with this project, first of all we flash the memory of the Wi-Fi module (ESP8266) to avoid any garbage values in our readings, then moving on to the next step we use some AT commands to set the module in the Wi-Fi mode and search for the available access points and then connect to any of them. If the module gets connected, it is well and good otherwise go back to the basic AT Commands then retry to connect which connects our microcontroller to the Wi- Fi. Then the next step is for taking inputs from the respective sensors in the microcontroller, now after obtaining values from the sensors, we need to convert the 5 volt logic of to the 3.3 volt logic as the Wi-Fi module works in 3.3 volt logic, after doing that use the channel API key to transmit the data/ input from the sensor to the channel and display them graphically on the space provided by the channel and for more understanding the whole process has been depicted. In this the components used in the project are represented in the form of blocks and shows how we carried out our work.

First of all using all the 4 types of sensors collected data then this data is latched in the microcontroller, then after performing all the basic requirements required by the Wi-Fimodule, connect our microcontroller to the access pointand then finally we upload the data to the channel. H_0 : The data is normally distributed.

H_1 :The data is not normally distributed.

V. RESULT &CONCLUSION

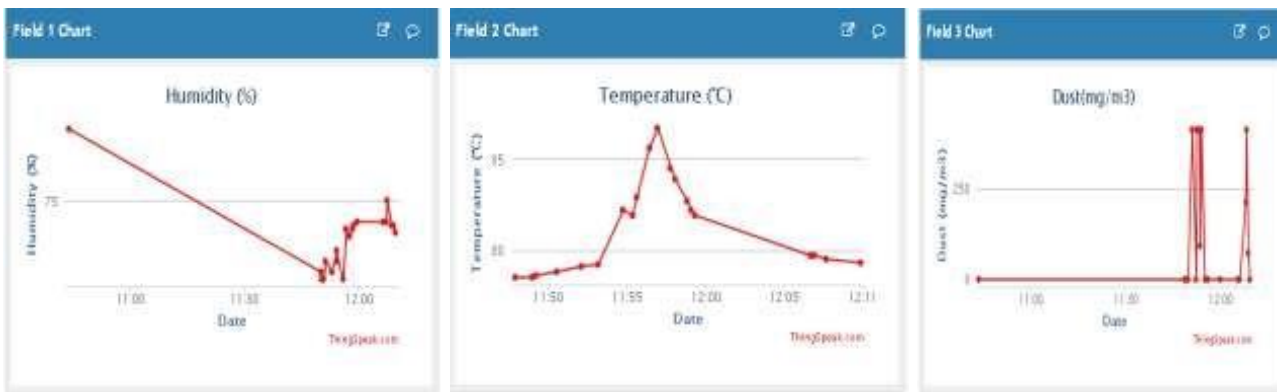

Figure 2 Result of testing sensors

The proposed system for the air quality monitoring with IoT Based Notification has been develop and tested. The system composed of two kinds of sensor particularly Dust sensor and the gas sensor. The study used arduino nano, DHT11 Sensors, and Sharp GP2Y10 10AU0F Optical Dust Sensors in the development of the proposed system. The integration of two sensors for each kind of sensor and average the readings of the sensor provides a stable reading. The proposed system provides a mechanism of sending sensor data wirelessly. on the system provides the IoT-Based notifications through information dissemination if the system exceeds a certain threshold and needs to inform the individuals whose emails have been included in the system.

VI. APPLICATION

Monitoring pollution at different levels up an urban high rise building to understand exposure with windows openAssessing employee pollutant exposure with indoor/outdoor air quality monitoring Roadside pollution Monitoring . Industrial Perimeter Monitoring. Site selection for reference monitoring stations. Indoor Air Quality Monitoring. To make this data available to the common man

REFERENCES

- [1]Jadhav Aditya, "Industrial Air Pollution Monitoring and Analysis System", International Journal of Advanced Research in Computer Science and Software Engineering Volume 6, Issue 3, March 2016.
- [2] Marina Sruthi.M, "Smart Pollution Detection and Tracking System Embedded With AWS IOT Cloud, International Journal of Advanced Research in Computer Science and Software Engineering Volume 6, Issue 4, April 2016.
- [3] Anita kulkarni, "Automated System for Air Pollution Detection and Control in Vehicles", International Journal of Advanced Research in Electrical ,Electronics and Instrumentation Engineering Vol. 3, Issue 9, September 2014.
- [4] Nihal Kularatna, "An Environment Air Pollution Monitoring System", IEEE 1451 Standard for Low Cost Requirements IEEE Sensors Vol:8; pp:415422; Apr:2008.
- [5] Prakash Doraiswamy, "Measuring Air Pollution Inside And Outside of Diesel Truck Cabs", International Journal ofAdvanced Research in Electrical ,Electronics and Instrumentation Engineering Vol. 3, Issue 9, September 2014
- [6]Preethichandra, D. (6-9 May 2013). "Design of a Smart Indoor Air Quality Monitoring Wireless Sensor Network for Assisted Living." Paper presented at Instrumentation and Measurement Technology Conference (I2MTC), 2013 IEEE International. Minneapolis, MN. ISSN 1091- 5281. DOI 10.1109/I2MTC.2013.6555624. (pp. 1306 – 1310).
- [7]Ferdoush, Sheikh, and Xinrong Li. "Wireless Sensor Network System Design Usingarduino nano and Arduino for Environmental Monitoring Applications." *Procedia Computer Science* 34 (2014), 103-110. doi:10.1016/j.procs.2014.07.059.
- [8] Sonali, D., Venkatasubramanian, K. A (2016). "Raspberry-PI based IOT system for measuring the environmental parameters to monitor the pollution level using IBM Bluemix," *Pakistan Journal of Biotechnology*, 13, pp. 231-235.
- [9] Balasubramaniyan, C., Manivannan, D. (2016). "IoT enabled Air Quality Monitoring System (AQMS) usingarduino nano." *Indian Journal of Science and Technology*, 9 (39), art. no. 90414.Jadhav, Gaurav, Kunal Jadhav, and Kavita Nadlamani. "Environment Monitoring System using Raspberry-Pi." *International Research Journal of Engineering and Technology (IRJET)*3, no. 4 (April 2016).
- [10]Jadhav, Gaurav, Kunal Jadhav, and Kavita Nadlamani. "Environment Monitoring System using Raspberry-Pi." *International Research Journal of Engineering and Technology (IRJET)* 3, no. 4 (April 2016).
- [11]Rohani, Mohd F., Noor A. Ahmad, Shamsul Sahibuddin, and Salwani M. Daud. "OPC Protocol Application for Real-Time Carbon Monitoring System for Industrial Environment." *International Journal of Electrical and Computer Engineering (IJECE)* 7, no. 2 (April 2017), 1051. doi:10.11591/ijece.v7i2.pp1051-1059.
- [12]Susanto, Dwi, Kudang B. Seminar, Heru Sukoco, and Liyantono Liyantono. "Parallel Processing Implementation on Weather Monitoring System for Agriculture." *Indonesian Journal of Electrical Engineering and Computer Science* 6, no. 3 (June 2017), 682. doi:10.11591/ijeecs.v6.i3.pp682-687.
- [13] Mekki, Marwa, and Osman Abdallah. "Development of a Wireless Sensors Network for Greenhouse Monitoring and Control." *Indonesian Journal of Electrical Engineering and Informatics (IJEI)* 5, no. 3 (September 2017), 270-274.
- [14]Abd Allah, Osman, Mohammed Abdalla, Suliman Abdalla, Amin Babiker, and Alaa Awad Allah. "Universal Data Logger System for Environmental Monitoring Applications." *Indonesian Journal of Electrical Engineering and Informatics (IJEI)* 5, no. 2 (June 2017), 131-136.
- [15]Baharun, A. N., N. A. Murad, and N. N. Malik. "Harmful Gases Profiling in Meru Menora Tunnel using SICK Sensor." *TELKOMNIKA (Telecommunication Computing Electronics and Control)* 15, no. 2 (June 2017), 888-894. Montanaro, Teodoro, Fulvio Corno, Carmelo Migliore, and Pino Castrogiovanni. "SmartBike: an IoT Crowd Sensing Platform for Monitoring City Air Pollution." *International Journal of Electrical and Computer Engineering (IJECE)* 7, no. 6 (December 2017), 3602. doi:10.11591/ijece.v7i6.pp3602-3612